

# **Datasheet**

## **Three-phase BLDC Motor Controller with Built-in Pre-driver FT8213Q**

Fortior Technology (Shenzhen) Co., Ltd

## Contents

<b>1 System Introduction .....</b>	<b>3</b>
1.1 Overview .....	3
1.2 Applications .....	3
1.3 Features .....	3
1.4 Typical Application Diagram .....	4
1.5 Functional Block Diagram .....	5
1.5.1 FT8213Q .....	5
1.6 Pinout Diagram.....	6
1.6.1 FT8213Q QFN28.....	6
1.7 Pin Definitions .....	7
1.7.1 FT8213Q QFN28 Pins .....	7
<b>2 Package Information .....</b>	<b>9</b>
2.1 FT8213Q QFN28_5X5 .....	9
<b>3 Ordering Information .....</b>	<b>10</b>
<b>4 Electrical Characteristics .....</b>	<b>11</b>
4.1 Absolute Maximum Ratings .....	11
4.2 Global Electrical Characteristics .....	11
4.3 Protection Electrical Characteristics .....	12
4.4 Speed Control with Analog Voltage .....	12
4.5 IO Electrical Characteristics (SCL/SDA/SPEED/FG/DIR) .....	12
4.6 Package Thermal Resistance .....	12
<b>5 Function Descriptions.....</b>	<b>13</b>
5.1 Operating Modes .....	13
5.2 Communication Interfaces .....	13
5.3 Speed Control.....	13
5.3.1 Speed Control Modes .....	13
5.3.2 Speed Control Curve .....	13
5.4 Protection Features.....	14
5.5 FG .....	14
5.5.1 Frequency Multiplication and Division of FG .....	14
5.5.2 FG Output in Open-loop Control Mode .....	15
5.6 RD.....	15
<b>6 Revision History.....</b>	<b>17</b>

## FT8213Q Three-phase BLDC Motor Controller with Built-in Pre-driver

### 1 System Introduction

#### 1.1 Overview

FT8213Q is a highly integrated IC with built-in pre-driver specially designed for three-phase BLDC motor drive applications. It supports sensorless FOC and designs with a  $1\Omega$  internal  $R_{dson}$ . Due to a high level of integration, the chip has few peripheral components and features with low noise and small torque ripple. Motor parameters, startup control parameters and speed regulation modes are stored in EFUSE. PWM, analog voltage input or I<sup>2</sup>C interface is available for motor speed regulation. Moreover, the chip integrates speed indicator to read motor speed in real time via FG pin or I<sup>2</sup>C interface. Constant speed control mode, constant air flow control mode, constant current control mode or open-loop control mode is optional. In addition, the chip is secured with a wide range of protection features, including phase loss protection, over-voltage lockout (OVLO), over-current protection (OCP), under-voltage lockout (UVLO), current-limiting protection (CLP), temperature sensor detect (TSD), motor lock protection (MLP), etc. Sleep-mode current of the chip is about 45 $\mu$ A.

#### 1.2 Applications

Refrigerator fans, cooling fans, water pumps, etc.

#### 1.3 Features

- Input supply voltage: 5V ~ 18V
- $R_{dson}$ :  $1\Omega$  (high-side MOS + low-side MOS)
- Drive current: 1A
- No Hall-based sensor is required
- FOC control to reduce motor noise and vibration
- Motor parameters, startup control parameters and speed regulation mode are stored in EFUSE
- I<sup>2</sup>C, PWM or analog voltage input interface for motor speed regulation
- Constant speed control mode, constant air flow control mode, constant current control mode or open-loop control mode is optional
- Forward or reverse rotation selectable
- Motor speed indication or motor block indication is configurable
- Sleep-mode current: 45 $\mu$ A
- Wake-up through SPEED pin or I<sup>2</sup>C interface
- Configurable I<sup>2</sup>C address
- Phase loss protection
- Over-voltage lockout (OVLO)
- Over-current protection (OCP)
- Under-voltage lockout (UVLO)
- Current-limiting protection (CLP)
- Temperature sensor detect (TSD)
- Motor lock protection (MLP)

### 1.4 Typical Application Diagram

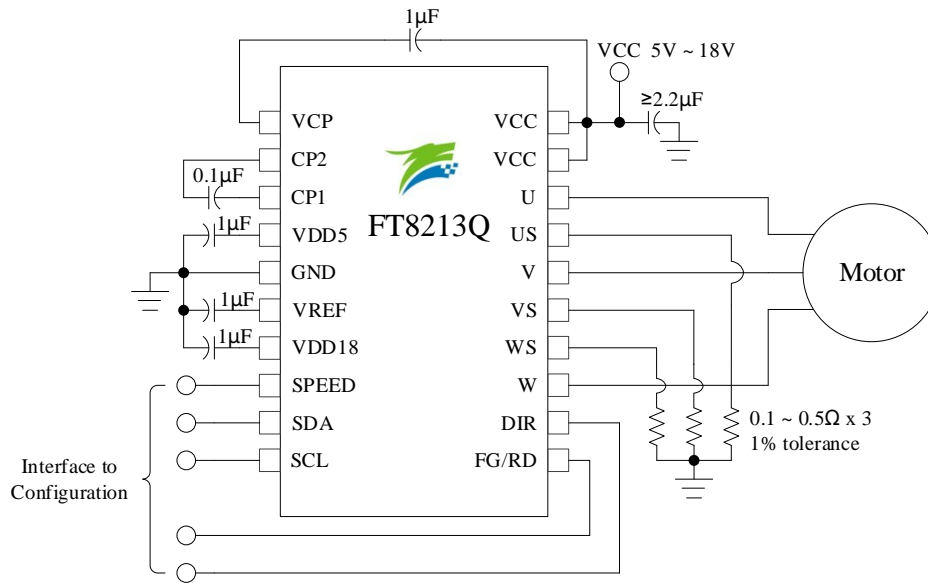

Figure 1-1 Typical Application Diagram of FT8213Q

## 1.5 Functional Block Diagram

### 1.5.1 FT8213Q

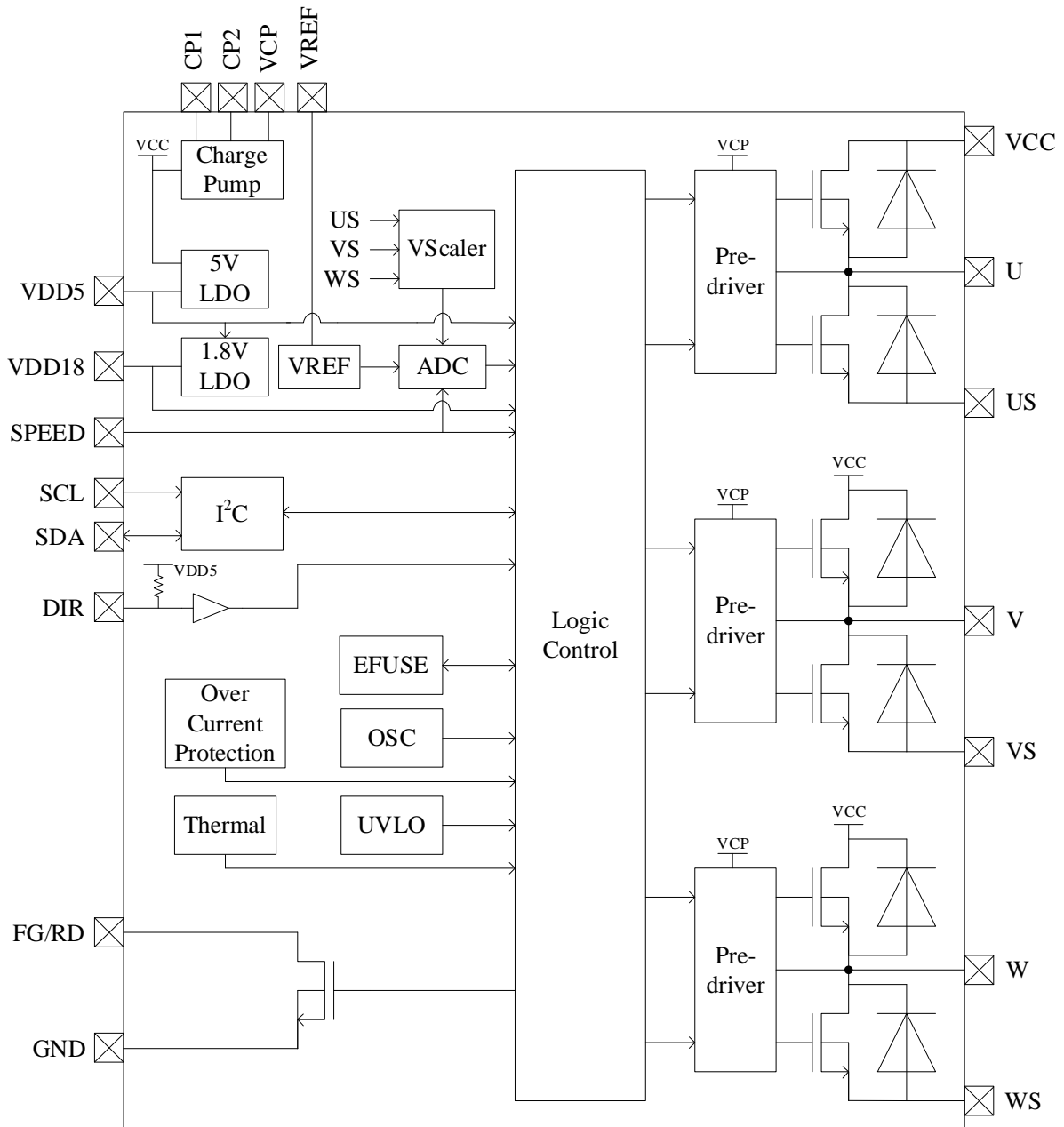

Figure 1-2 Functional Block Diagram of FT8213Q



## 1.7 Pin Definitions

The IO types are defined as follows:

- DI = Digital Input
- DO = Digital Output
- DB = Digital Bidirectional
- AI = Analog Input
- AO = Analog Output
- P = Power Supply

### 1.7.1 FT8213Q QFN28 Pins

Table 1-1 FT8213Q QFN28 Pin Descriptions

Pin	FT8213Q QFN28	IO Type	Description
VDD5	1	P	5V LDO output with a 1 $\mu$ F ~ 4.7 $\mu$ F capacitor connected to ground
GND	2	P	Ground
VREF	3	AI	ADC reference voltage, with a 1 $\mu$ F external capacitor connected to ground
VDD18	4	P	1.8V LDO output with a 1 $\mu$ F external capacitor connected to ground
NC	5	-	Not connected
SPEED	6	DI	Speed control input, PWM or analog voltage, determined by EFUSE; Internal pull-up resistor is available in PWM input mode; When I <sup>2</sup> C is selected for motor speed regulation, this pin becomes inactive and is left floating or connected with VDD5.
SDA	7	DB	I <sup>2</sup> C SDA in slave mode, with open-drain output, maximum speed rate at 400kHz and a configurable internal pull-up resistor
SCL	8	DB	I <sup>2</sup> C SCL in slave mode, with open-drain output, maximum speed rate at 400kHz and a configurable internal pull-up resistor
FG/RD	9	DO	Motor speed signal or motor block indication, with open-drain output and a configurable internal pull-up resistor
DIR	10	DI	Motor rotation control, with built-in pull-up resistor 1: Forward output phase sequence: U --> V --> W. 0: Reverse output phase sequence: U --> W --> V.
NC	11	-	Not connected
W	12	DO	W-phase output
W	13	DO	W-phase output
WS	14	AI	W-phase ground input
WS	15	AI	W-phase ground input
VS	16	AI	V-phase ground input
VS	17	AI	V-phase ground input
V	18	DO	V-phase output
V	19	DO	V-phase output
US	20	AI	U-phase ground input
US	21	AI	U-phase ground input
U	22	DO	U-phase output
U	23	DO	U-phase output
VCC	24	P	Power input, 5V ~ 18V, with a capacitor of 2.2 $\mu$ F or above connected to ground (depends on actual applications)

<b>Pin</b>	<b>FT8213Q QFN28</b>	<b>IO Type</b>	<b>Description</b>
VCC	25	P	Power input
VCP	26	P	Charge pump output, with a 1 $\mu$ F ~ 4.7 $\mu$ F capacitor connected to VCC pin
CP2	27	AO	Charge pump pin, with a 0.1 $\mu$ F capacitor connected to CP1 pin
CP1	28	AO	Charge pump pin, with a 0.1 $\mu$ F capacitor connected to CP2 pin

## 2 Package Information

### 2.1 FT8213Q QFN28\_5X5

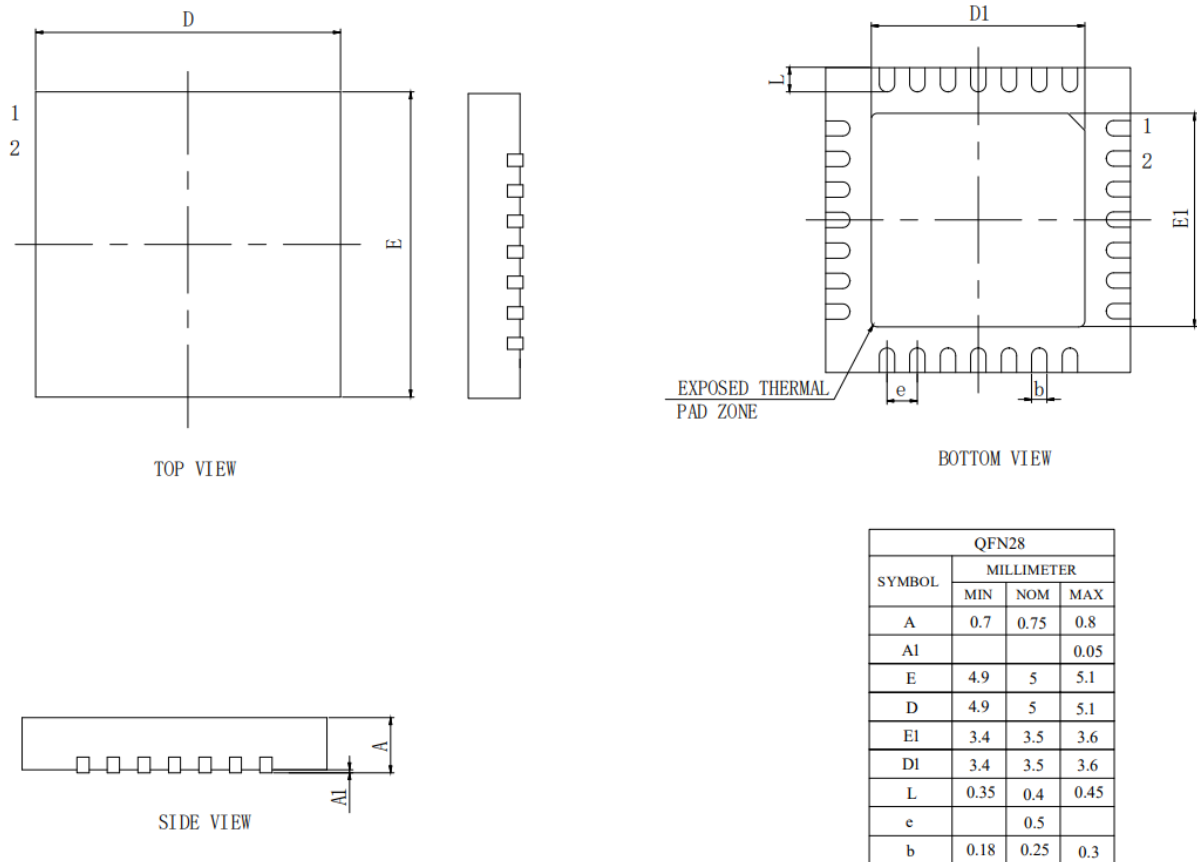

Figure 2-1 FT8213Q QFN28\_5X5 Package Drawings and Dimensions

**3 Ordering Information**

Table 3-1 Model Selections

Model	Power Supply (V)	R <sub>dson</sub> (High Side + Low Side) (Ω)	Drive Current (A)	Control Features							Protection Features						Operating Temperature T <sub>j</sub> (°C)	Lead-free	Package
				Drive Type	Speed Regulation			Forward and Reverse Rotation	Initial Position Detection	Phase Loss Protection	OVLO	OCP	UVLO	CLP	TSD	MLP			
					I <sup>2</sup> C	PWM	Analog Voltage												
FT8213Q	5 ~ 18	1	1	Sensorless Sine-wave	√	√	√	√	√	√	√	√	√	√	√	√	-40 ~ 150	√	QFN28 (5x5 mm)

## 4 Electrical Characteristics

### 4.1 Absolute Maximum Ratings

 Table 4-1 Absolute Maximum Ratings<sup>[1]</sup>

Parameter	Test Conditions	Min.	Typ.	Max.	Unit
Operating Ambient Temperature $T_A$ <sup>[2]</sup>		-40	-	85	°C
Operating Ambient Temperature $T_A$ <sup>[2]</sup>	FT8213Q, $I_{VCC} \leq 0.5A$	-40	-	105	°C
Operating Junction Temperature $T_J$		-40	-	150	°C
Storage Temperature		-55	-	150	°C
VCC Supply Voltage		-0.3	-	22	V
VCC to VSS Spike Voltage	Peak Duration < 500ms	-0.3	-	26	V
VCP to VCC Voltage		-0.7	-	6.5	V
US/VS/WS Voltage		-0.7	-	0.7	V
SPEED/SDA/SCL/DIR/FG Voltage		-0.3	-	VDD5 + 0.3	V

Notes:

[1] Stress values greater than "Absolute Maximum Ratings" listed above may cause irremediable damages to the device. These are stress ratings only, and it is NOT recommended to use your device in conditions that go beyond these stress ratings. Exposure to "Absolute Maximum Ratings" for extended periods may affect device reliability.

[2] It is not mandatory provided that Operating Junction Temperature  $T_J$  does not exceed the maximum specified.

### 4.2 Global Electrical Characteristics

Table 4-2 Global Electrical Characteristics

( $T_A = 25^\circ\text{C}$  and  $V_{CC} = 12\text{V}$  unless otherwise specified)

Parameter	Test Conditions	Min.	Typ.	Max.	Unit
VCC Operating Voltage		5	-	18	V
VDD5 Output Voltage	$T_A = -40^\circ\text{C} \sim 85^\circ\text{C}$	4.8	5	5.2	V
$V_{REF}$ Reference Voltage	$T_A = -40^\circ\text{C} \sim 85^\circ\text{C}$	4.3	4.5	4.7	V
$I_{VCC}$ Operating Current <sup>[1]</sup>		-	5	-	mA
$I_{VCC}$ Sleep-mode Current		-	45	100	$\mu\text{A}$
$R_{dson}$ (High-side MOS + Low-side MOS)		-	1	-	$\Omega$

Note:

[1] Characteristics may vary with different configurations.

### 4.3 Protection Electrical Characteristics

Table 4-3 Protection Electrical Characteristics

Parameter	Test Conditions	Min.	Typ.	Max.	Unit
V <sub>OVLP</sub> VCC OVLO Threshold Voltage		22	24	26	V
V <sub>OVLP_HYS</sub> VCC OVLO Hysteresis Voltage		-	0.5	-	V
V <sub>UVLO_F</sub> VCC UVLO Threshold Voltage		-	4.4	4.6	V
V <sub>UVLO_HYS</sub> VCC UVLO Hysteresis Voltage		-	0.2	-	V
I <sub>OCP</sub> OCP Threshold Current		1.6	1.7	-	A
T <sub>TSD</sub> TSD Threshold Temperature		-	160	-	°C
T <sub>TSD_HYS</sub> TSD Hysteresis Temperature		-	15	-	°C

### 4.4 Analog Voltage Input for Speed Control

Table 4-4 Analog Voltage Input for Speed Control

Parameter	Test Conditions	Min.	Typ.	Max.	Unit
V <sub>SPD</sub> MAX		-	VREF	-	V

### 4.5 IO Electrical Characteristics (SCL/SDA/SPEED/FG/DIR)

Table 4-5 IO Electrical Characteristics (SCL/SDA/SPEED/FG/DIR)

Parameter	Test Conditions	Min.	Typ.	Max.	Unit
V <sub>IH</sub> High-level Input Voltage		2.5	-	-	V
V <sub>IL</sub> Low-level Input Voltage		-	-	0.6	V
I <sub>OL</sub> Output Sink Current	V <sub>out</sub> = 0.3V	5	-	-	mA
F <sub>IN</sub> PWM Input Frequency		1	-	100	kHz

### 4.6 Package Thermal Resistance

Table 4-6 QFN28 Package Thermal Resistance

Parameter	Test Conditions	Value	Unit
Junction-to-ambient Thermal Resistance $\theta_{JA}$ <sup>[1]</sup>	JEDEC standard, 2S2P PCB	43	°C/W
Junction-to-case Thermal Resistance $\theta_{JC}$ <sup>[1]</sup>	JEDEC standard, 2S2P PCB	15	°C/W

Note:

[1] The actual measurements may vary depending on the conditions.

## 5 Function Descriptions

### 5.1 Operating Modes

The chip works in normal mode (Normal) or sleep mode (Sleep).

### 5.2 Communication Interfaces

The chip integrates I<sup>2</sup>C interface for slave devices with programmable address starting from "0x00" and maximum transmission speed less than 400kHz.

### 5.3 Speed Control

#### 5.3.1 Speed Control Modes

The chip supports three types of speed control input interface: PWM, analog voltage and I<sup>2</sup>C, and only one of them can be chosen at a time. PWM control mode and analog voltage control mode support inverting input. When voltage-loop control mode is selected, motor speed can be controlled by varying the supply voltage.

#### 5.3.2 Speed Control Curve

The control waveform is presented as below, where x-coordinate refers to the duty cycle of PWM input, and y-coordinate refers to the output, which represents different physical quantities in different control modes.

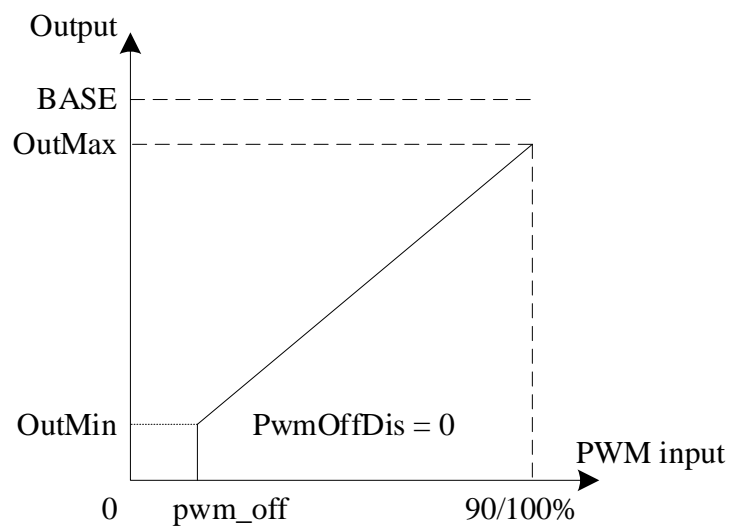

Figure 5-1 Output Curve at PwmOffDis = 0

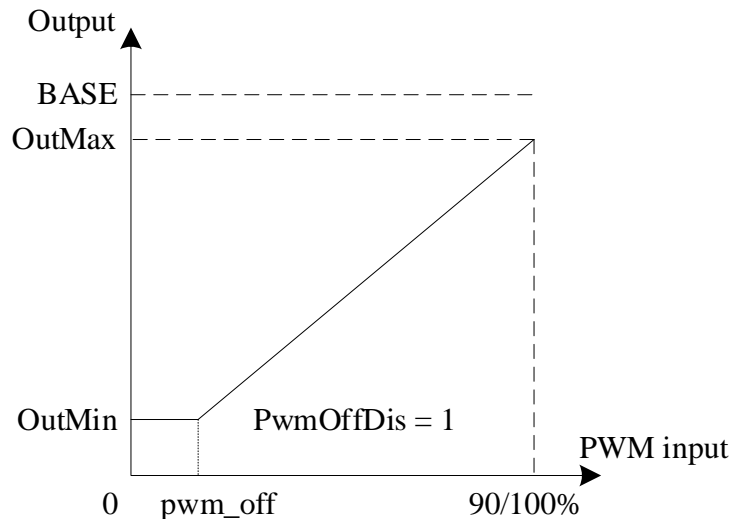

Figure 5-2 Output Curve at PwmOffDis = 1

## 5.4 Protection Features

The chip supports protection features, including phase loss protection, over-voltage lockout (OVLO), over-current protection (OCP), under-voltage lockout (UVLO), current-limiting protection (CLP), temperature sensor detect (TSD), motor lock protection (MLP), etc.

## 5.5 FG

The chip delivers motor speed signal or motor status via FG/RD pin.

### 5.5.1 Frequency Multiplication and Division of FG

Configuring FG/RD to FG outputs FG signal, that is, FG/RD pin is selected to output FG signal. The output frequency of FG signal is determined by FGDIV (frequency division coefficient) and FGMUL (frequency multiplication coefficient). FGMUL can be set as 1, 2, 3 and 4, while FGDIV as 1, 1/3, 1/4 and 1/5.  $k$  (coefficient of output frequency) =  $FGMUL * FGDIV$ .

Table 5-1 FG Configurations

Coefficient of Output Frequency (k)		FGMUL			
		1	2	3	4
FGDIV	1	1	2	3	4
	1/3	1/3	2/3	3/3	4/3
	1/4	1/4	2/4	3/4	4/4
	1/5	1/5	2/5	3/5	4/5

The number of FG signals in one mechanical cycle is equal to  $pp * k$  ( $pp$  refers to pole-pair number of the motor).

Example: For a 4-pole-pair motor, if FGMUL is set as 3 and FGDIV as 1/4, that is,  $k = 3/4$ , three FG signals are displayed in one mechanical cycle ( $4 * 3/4$ ).

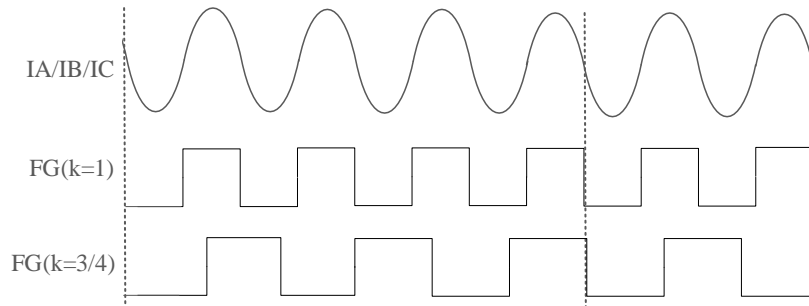

Figure 5-3 FG Output Waveform at  $k = 1$  and  $k = 3/4$

### 5.5.2 FG Output in Open-loop Control Mode

FG pin outputs feedback signal to indicate motor speed in close-loop control mode. However, in open-loop control mode, the FG signal does not directly reflect motor's actual speed. Instead, the chip outputs FG signal or high-level signal based on FGSet configuration.

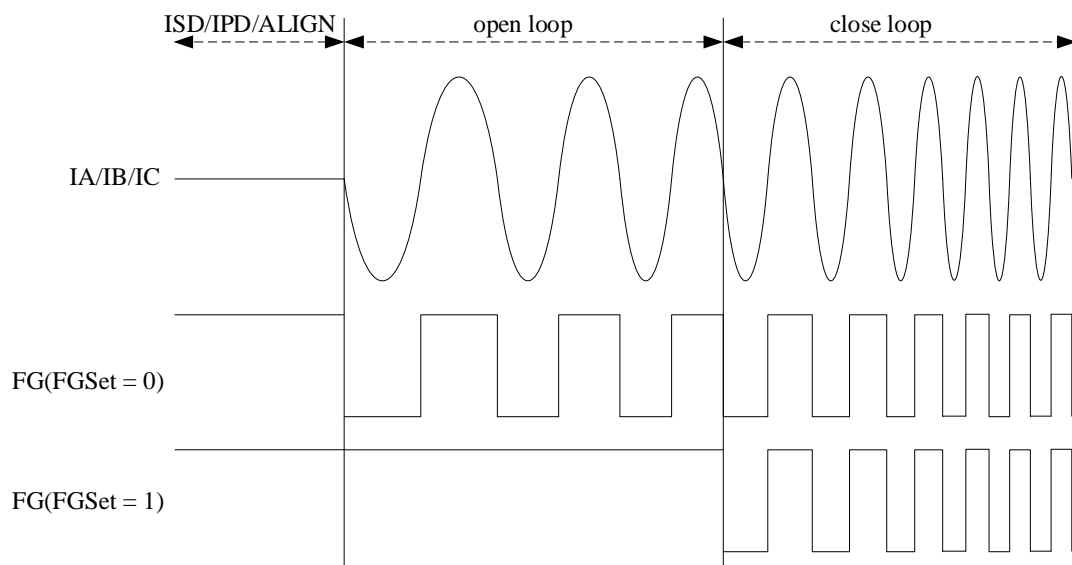

Figure 5-4 FG Output Waveform

### 5.6 RD

RD pin indicates operating status of the motor. Configuring FG/RD to RD outputs RD signal, that is, FG/RD pin is selected to output RD signal. The chip outputs different RD signals according to FGSet configuration.

- FGSet = 0: RD = 0 in open-loop or close-loop control mode, and RD = 1 in other control modes.
- FGSet = 1: RD = 0 in close-loop control mode, and RD = 1 in other control modes.

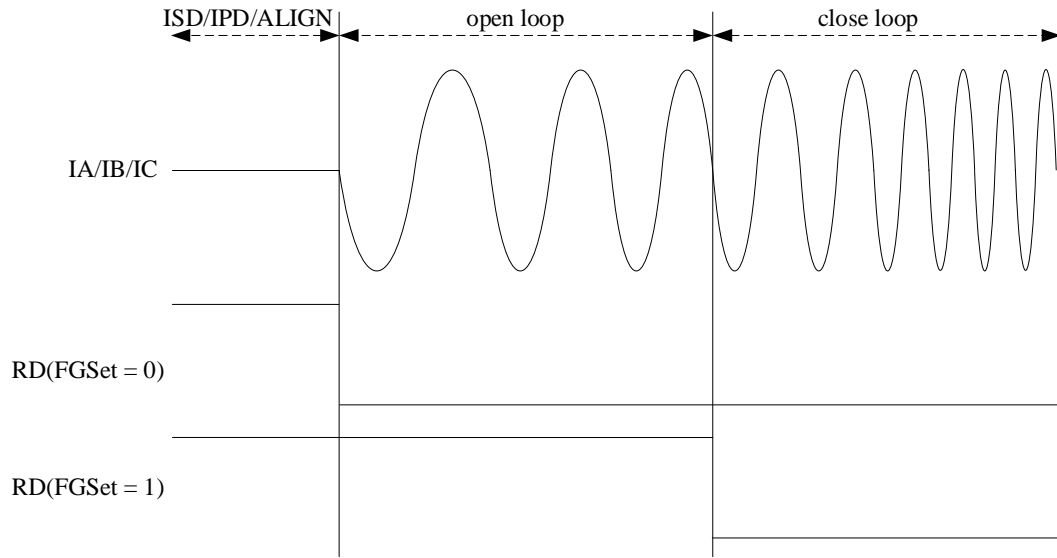

Figure 5-5 RD Output Waveform

## 6 Revision History

Rev.	Description	Date	Prepared By
V1.1	First release, translated from Chinese version 1.1	2021/05/28	Husy Hu
V1.2	Modified the name of section “1.6 Packaging” as “1.6 Pinout Diagram”.	2022/05/21	Bruce Long
V1.3	<ol style="list-style-type: none"> <li>1. Modified the pin name “FG” as “FG/RD”;</li> <li>2. Added “phase loss protection” in section 1.1 Overview;</li> <li>3. Added “current-limiting protection (CLP)” in sections 1.1 Overview, 1.3 Features and 3 Ordering Information;</li> <li>4. Modified the description “a configurable pull-up resistor” as “an internal configurable pull-up resistor” in section 1.7.1 FT8213Q QFN28 Pins;</li> <li>5. Corrected the maximum value “VCC + 6.5V” of VCP to VCC Voltage in Table 4-1 Absolute Maximum Ratings as “6.5V”;</li> <li>6. Modified maximum transmission speed of I<sup>2</sup>C interface “1Mbps” in section 5.2 Communication Interfaces as “400kHz”;</li> <li>7. Updated descriptions in section 5.5.1 Frequency Multiplication and Division of FG;</li> <li>8. Modified “FGRDSet” in section 5.5.2 FG Output in Open-loop Control Mode and 3.6 RD as “FGSet”;</li> <li>9. Updated Figure 2-1 FT8213Q QFN28_5X5 Package Drawings and Dimensions;</li> <li>10. Deleted “Please refer to speed regulating table” in section 5.3.2 Speed Control Curve;</li> <li>11. Proofread the overall document, reorganized document structure and standardized document format.</li> </ol>	2023/10/25	Eric Deng
V1.4	Modified the minimum value “-65°C” of Storage Temperature in Table 4-1 Absolute Maximum Ratings as “-55°C”, and added the parameter “VCC to VSS Spike Voltage” in the table.	2023/12/13	Eric Deng
V1.5	<ol style="list-style-type: none"> <li>1. Updated Figure 1-1 Typical Application Diagram of FT8213Q;</li> <li>2. Updated Figure 1-2 Functional Block Diagram of FT8213Q;</li> <li>3. Modified IO Type “DI/AI” of the SPEED pin in Table 1-1 FT8213Q QFN28 Pin Descriptions as “DI”;</li> <li>4. Modified typical value “165°C” of T<sub>TSD</sub> TSD Threshold Temperature in section 4.3 Protection Electrical Characteristics as “160°C”, and typical value “4.5V” of V<sub>UVLO_F</sub> VCC UVLO Threshold Voltage as “4.4V”.</li> </ol>	2025/04/10	Eric Deng

## Copyright Notice

Copyright by Fortior Technology (Shenzhen) Co., Ltd. All Rights Reserved.

Right to make changes — Fortior Technology (Shenzhen) Co., Ltd. reserves the right to make changes in the products - including circuits, standard cells, and/or software - described or contained herein in order to improve design and/or performance. The information contained in this manual is provided for the general use by our customers. Our customers shall ensure that they take appropriate action so that their use of our products does not infringe upon any patents. It is the policy of Fortior Technology (Shenzhen) Co., Ltd. to respect the valid patent rights of third parties and not to infringe upon or assist others to infringe upon such rights.

This manual is copyrighted by Fortior Technology (Shenzhen) Co., Ltd. You may not reproduce, transmit, transcribe, store in a retrieval system, or translate into any language, in any form or by any means, electronic, mechanical, magnetic, optical, chemical, manual, or otherwise, any part of this publication without the expressly written permission from Fortior Technology (Shenzhen) Co., Ltd. You may not alter or remove any copyright or other notice from copies of this content.

If there are any differences between the Chinese and the English contents, please take the Chinese version as the standard.

### **Fortior Technology (Shenzhen) Co., Ltd.**

Room 203, 2/F, Building No.11, Keji Central Road 2,  
Software Park, High-Tech Industrial Park, Shenzhen, P.R. China 518057  
Tel: 0755-26867710  
Fax: 0755-26867715  
URL: <http://www.fortiortech.com>

### **Contained herein**

**Copyright by Fortior Technology (Shenzhen) Co., Ltd. All rights reserved.**